

THREE-PHASE ISOLATING TRANSFORMERS

- Compliant with standard **EN 61558-2-4**
- Standard voltages
Input winding **230 V** or **400 V**
Output winding **230 V** or **400 V**
- Other voltages available on request
- Electrostatic screen available on request
- Protection rating **IP00**
- Electrical protection rating **I**
- Thermal insulation class **B**
- Fixing brackets compliant with DIN standards
- Connection terminals **IP 20**

KVA	A1	B1	A2	A4	B2	A3	B3	C	KG	W fe	W tot	Vcc %	Δv	BOX
0,5	180	105	111	-	75	6	9	162	8	12	38	6	6	A
1	240	120	200	-	76	10	20	215	14	19	88	6	5	B
1,5	240	130	200	-	86	10	20	215	17	24	110	6	5	B
2	240	140	200	-	96	10	20	215	20	28	125	5	5	B
2,5	300	130	250	-	100	10	20	265	26	37	150	5	4,5	C
3	300	130	250	-	100	10	20	265	27	37	155	5	4,5	C
3,5	300	140	250	-	110	10	20	265	31	45	175	5	4,5	C
4	300	165	250	-	120	10	20	278	35	52	190	5	4,5	C
5	300	175	250	-	130	10	20	278	40	59	245	5	4	C
6	360	165	325	280	113	10	30	325	45	64	310	4,5	4	D
7	360	175	325	280	123	10	30	325	50	75	380	4,5	4	D
8	360	240	325	280	133	10	30	325	60	85	420	4,5	4	D
10	420	240	375	300	125	10	30	375	80	105	510	4,5	3,5	E
12	420	255	375	300	135	10	30	375	90	115	530	4,5	3,5	E
15	480	290	430	375	155	12	30	430	120	155	750	4	3,5	F
20	480	300	430	375	165	12	30	430	150	195	880	4	3	F
25	480	310	430	375	175	12	30	430	165	215	995	4	3	F
30	480	340	430	375	195	12	30	430	195	250	1120	4	3	F
40	600	390	510	360	180	12	30	535	215	315	1220	4	2,5	G
50	600	400	510	360	190	12	30	535	235	340	1550	3,5	2,5	G
60	600	410	510	360	200	12	30	535	260	380	2150	3,5	2,5	G
63	600	420	510	360	210	12	30	535	275	400	2200	3	2,5	G
75	600	450	510	360	240	12	30	535	340	505	2400	3	2,5	H
100	600	450	510	360	240	12	30	535	340	525	2800	3	2,5	H

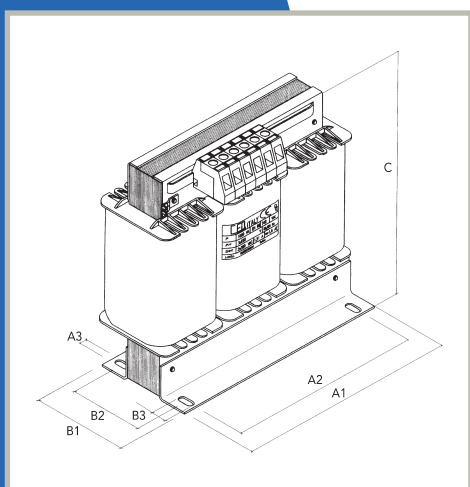

W fe = no-load losses
W tot = full-load losses
Vcc % = short-circuit voltage
 Δv = voltage drop from no-load to full-load

