

ENCLOSURES FOR THREE-PHASE TRANSFORMERS

- Protection rating: **IP 23**
- Other protection ratings available on request
- Standard colours: **RAL 7032** or **RAL 7035**
- Other colours available on request
- Powder coated
- Stainless steel available on request

MOD	A1	B1	A2	B2	B3	F	C1	C2	KG
A	270	220	135	180	150	8	300	275	4,5
B	310	255	200	215	180	8	345	320	6,5
C	370	320	200	280	250	8	400	375	8,5
D	430	320	300	280	250	8	450	425	11
E	490	380	300	340	310	8	500	475	14
F	530	380	400	350	320	8	550	525	15
G	650	420	400	390	360	8	650	600	20
H	910	615	605	585	590	8	900	840	30

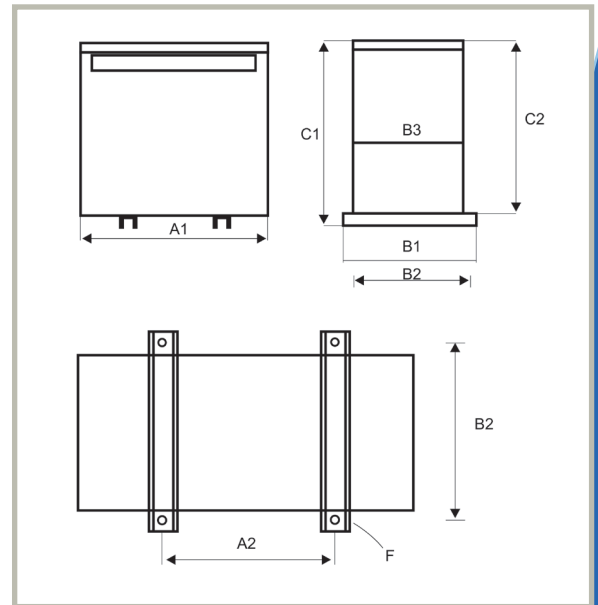

CE

